



ADVANCECUT 125 PLASMA CUTTER

OPERATING INSTRUCTIONS



👉 IMPORTANT!

To qualify for full 36 month warranty, you must register within 30 days of purchase. See inside for details.

Read these Operating Instructions Completely before attempting to use this machine. Save this manual and keep it handy for quick reference. Pay particular attention to the safety instructions we have provided for your protection. Contact your distributor if you do not fully understand anything in this manual.



CORROSION
RESISTANT



IGBT INVERTER
TECHNOLOGY



DIRECT
CURRENT



400V 50HZ
3 PHASE



PILOT
ARC START



SPIKE/
GENERATOR
SAFE



CNC
CUTTING



INTELLIGENT
PROTECTION
SYSTEM

www.strata.co.nz



ADVANCECUT 125

CONTENT

1 Overview.....	5
1.1 Features	5
1.2 Technical Data.....	5
1.3 Working Principle.....	6
1.4 Duty cycle and Over-heat.....	6
1.5 Volt-Ampere Characteristic	7
2 Installation & Operation	8
2.1 Layout for the front and rear panel	8
2.2 Installation & Operation.....	12
2.3 Plasma Cutting Guide	17
2.3.1 Cutting Guide	17
2.3.2 Operating Techniques	18
2.4 Troubleshooting	20
2.5 Operation environment.....	21
2.6 Operation Notices	21
3 Maintenance & Troubleshooting	23
3.1 Cutting gun maintenance	23
3.2 Troubleshooting Principle.....	23
3.3 Electrical schematic drawing.....	26
4 Safety.....	27
4.1 Symbols Explanation.....	27
4.2 Machine Operating warnings!.....	27
4.3 EMC device classification	33
4.4 EMC measure.....	34
4.5 Warning label.....	35
WARRANTY.....	36



ADVANCECUT 125

Congratulations on the purchase of your new Stata Welding Product!

The Strata range of Welding Products from Euroquip utilises the latest design technology and is engineered to produce welding products that combine market leading value, features and durability. Designed for the discerning operator, who seeks professional results and quality. Design emphasis is placed on simple design and functional operation. All Strata products are subject to stringent quality control and are designed and manufactured to New Zealand and Australian standards.

Common applications for Strata products include:

- Engineering
- Automotive
- Manufacturing
- Farming
- Industrial Maintenance and Repair

For more industrial welding solutions, check out the full Strata Range from Euroquip at:

www.strata.co.nz

Euroquip is a market leading provider of innovative power equipment solutions to a wide range of industries across Australasia.

Providing exceptional product support is a key component of Euroquip's market leading customer advantage program. As part of this program, it is required products to be registered with Euroquip to qualify for extended product support. Products that are not registered with Euroquip are supported by a base 12 month warranty only. Spare parts and after sales support may not be available for an unregistered product outside of the base warranty period. If a Euroquip dealer has not already registered your product, please register it online at www.euroquip.co.nz To access a physical registration form, please download one at www.euroquip.co.nz under the contact us tab.



STRATA

SUPERIOR WELDING PRODUCTS



• ADVANCECUT 125 •

PLASMA CUTTER

The AdvanceCut125 offers superior functionality in the Plasma cutting sector. Utilising IGBT module inverter technology and dual HF/Non HF arc starting systems, the user has the convenience of reliable high performance cutting. The AdvanceCut125 is the easy choice for your heavy duty plasma cutting needs.



- IGBT Module Inverter Technology for smooth & stable output, increased reliability, high duty cycle
- Dual HF/Non HF ARC starting system for high starting reliability and low EMF pollution
- Simple and clear display of all parameters on full colour LCD control panel
- Onboard air pressure sensor for accurate monitoring and control of compressed air supply pressure
- Designed for operating with automated CNC cutting equipment with interface connection
- Heavy Duty Italian TH-125 Plasma Torch Equipped as standard for superior cutting performance and consumable life
- Automatic Pilot Arc Control System providing increased cutting capability, especially for discontinuous cutting
- Intelligent Plasma Torch Protection System protects plasma torch from damage from incorrect air pressure, - consumables not in place, excessive pilot arc use.
- Protected external air regulator with water trap/ filter provides easy adjustment & serviceability
- Intelligent Machine Protection System with temperature, voltage and current sensors for increased reliability & safety
- Machine automatically shuts down if power supply phase loss occurs, to prevent damage.
- IP23 - protected against moisture, salt spray and corrosion
- Extreme stress tested to 550V in production for rugged reliability.
- Safe & Robust Euro Torch Connection to Machine
- Damage resistant industrial casing with front panel protection
- Set & test air pressure without the need to trigger the torch with air flow manual activation switch



CORROSION RESISTANT



IGBT INVERTER TECHNOLOGY



DIRECT CURRENT



400V 50HZ 3 PHASE



PILOT ARC START



SPIKE/GENERATOR SAFE



CNC CUTTING



INTELLIGENT PROTECTION SYSTEM

ADVANCECUT 125

DIMENSIONS:	WEIGHT:	INPUT POWER SUPPLY:	MAX. INPUT CURRENT:	GENERATOR CAPACITY:	CURRENT OUTPUT:	DUTY CYCLE:	PRODUCTION CUT CAPACITY	COMPRESSED AIR REQ.	STANDARDS:
660 x 240 x 445	33kg	400V AC 32A 50/60Hz	34A	25KVA	20-120A	60% @ 120A 100% @ 100A	Carbon Steel 50mm Aluminum 45mm	295L/min 6 Bar	EN60974-1:2012

* 36 Month Warranty only with online registration of product - www.strata.co.nz



ADVANCECUT 125

1 Overview

1.1 Features

- IGBT module inverter technology for smooth, stable output, increased reliability .
- Microprocessor control system for superior & dynamic arc characteristics.
- CNC interface connection.
- Euro connect torch system with safe & robust connection to machine.
- Advanced strata plasma torch with european torch head for superior cutting performance and consumable life.
- Non HF arc starting system for increased reliability and low EMF pollution.
- Automatic pilot arc control system for increased cutting capability and speed, especially for discontinuous cutting.
- Strong environmental protection against moisture, salt spray and corrosion .
- Intelligent protection system protects plasma torch from damage/incorrect /air pressure, consumables not in place, excessive pilot arc use.
- Air flow manual activation switch to set & test air pressure, pressure without the need to trigger the torch.
- 4.3 inch color LCD screen, easier to operate, real-time display of welding content.

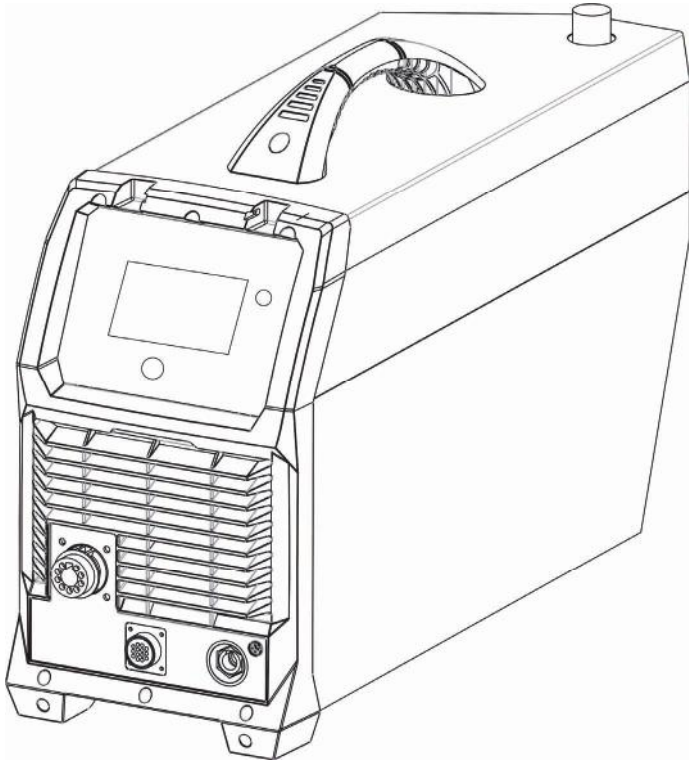

1.2 Technical Data

Parameters	Models	ADVANCECUT125
Rated input voltage (V)		3-380V/400V±10% 50/60Hz
Rated input current (A)		26
Rated input power (KW)		10.4
No-load voltage (V)		420V



ADVANCECUT 125

The max. cutting thickness to Carbon steel (mm)		≤ 35
Optimal cutting thickness (mm)	Carbon steel	≤ 25
	Stainless steel	≤ 25
	Aluminum	≤ 20
	Cuprum	≤ 14
Dimensions (mm)		660 x 240 x 445
Protection class		IP23
Insulation class		H
Net weight (kg)		24
Cooling method		AF

Note: The above parameters are subject to change with future machine improvement!

1.3 Working Principle

The working principle of the AdvanceCut series of Air Plasma Cutting machines is shown as the following figure. Three-phase 400V line frequency (50/60 Hz) AC is rectified into DC, then it is converted to medium frequency AC (about 20KHz) by inverter device (discrete IGBT), after reducing voltage by medium transformer (the main transformer) and rectified by medium frequency rectifier (fast recovery diode), and is outputted by inductance filtering. The circuit adopts current feedback control technology to insure current output stably. Meanwhile, the cutting current parameter can be adjusted continuously and steplessly to meet with the requirements of cutting craft.

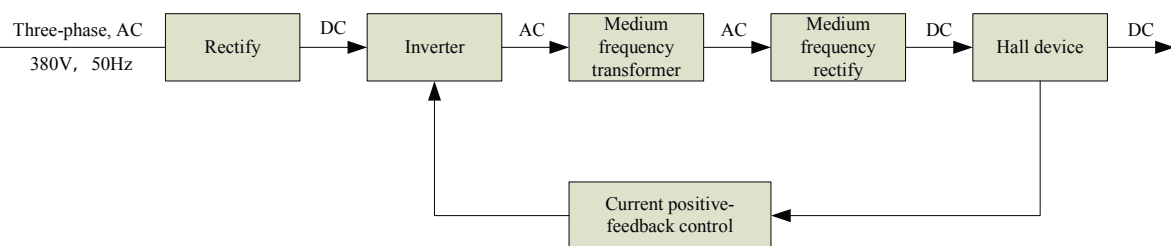

1.4 Duty cycle and Over-heat

The letter “X” stands for Duty Cycle, which is defined as the portion of the time a air plasma cutting machine can cut continuously with it’s rated output current within a certain time cycle (10 minutes).



ADVANCECUT 125

The relation between the duty cycle “X” and the output cutting current “I” is shown as the right figure.

If the plasma cutter is overheating, the IGBT over-heat protection sensing will send a signal to the plasma cutter control unit to cut the output cutting current OFF and light the over-heat pilot lamp on the front panel. In that case, the machine should not be cutting for 10-15 minutes to cool down with the fan running. When operating the machine again, the cutting output current or the duty cycle should be reduced.

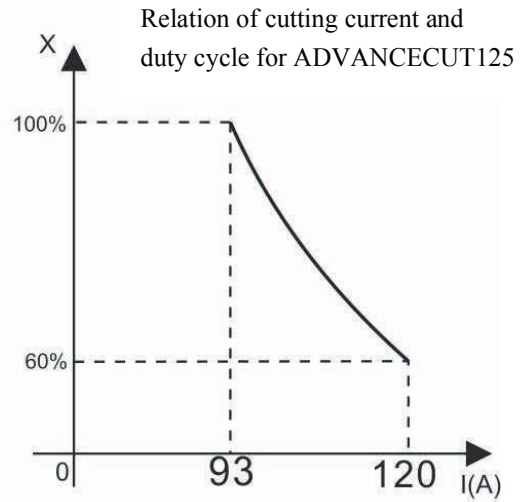

1.5 Volt-Ampere Characteristic

The AdvanceCut series of Air Plasma Cutting machines has excellent volt-ampere characteristic. Referring to the following graph. The relation between the rated loading voltage U_2 and welding current I_2 is as follows:

When $I_2 \leq 600A$, $U_2 = 80 + 0.4 I_2$ (V) ; When $165A < I_2 \leq 500A$, $U_2 = 130 + 0.1 I_2$ (V) ;

When $I_2 > 500A$, $U_2 = 180$ (V) .

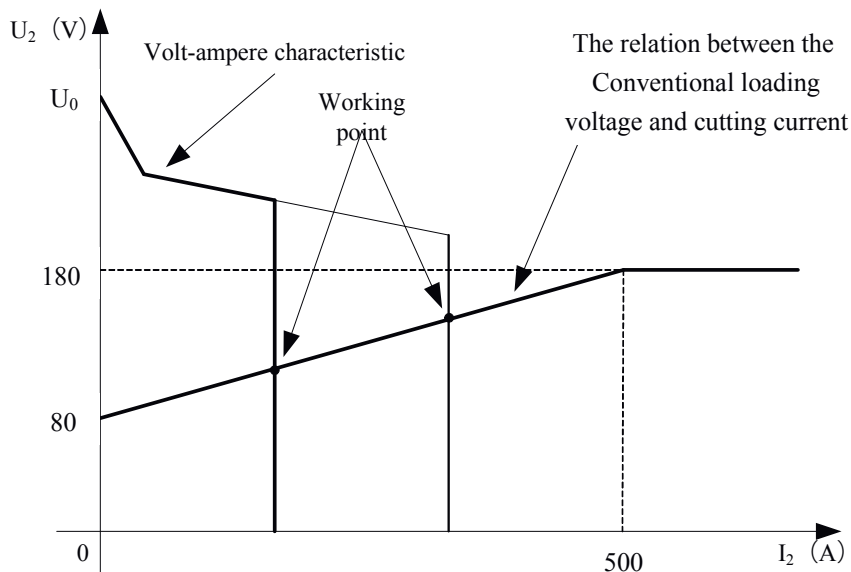

2 Installation & Operation

2.1 Layout for the front and rear panel

Front View

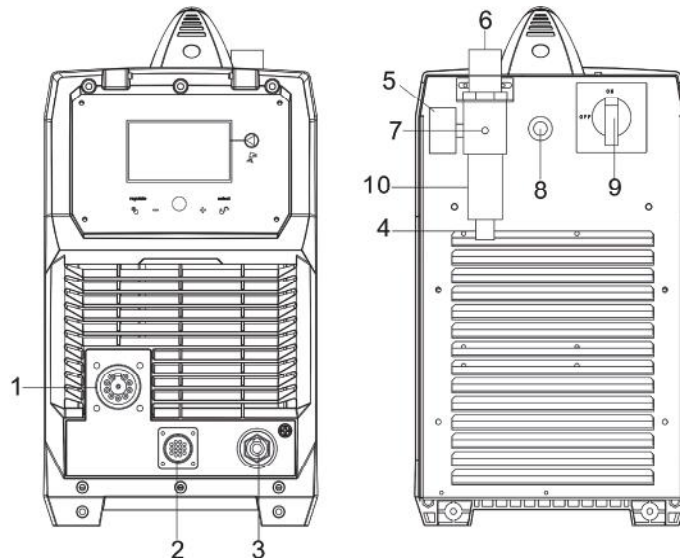

- (1) Plasma Torch Euro/ Central Connector.
- (2) CNC Interface Connection
- (3) Earth Lead Connection Socket.
- (4) Air Filter Condensate Drain Tube.
- (5) Air Pressure Regulator Outlet Pressure Gauge.
- (6) Air Pressure Regulator Knob.
- (7) Compressed Air Inlet.
- (8) Input Power Cable.
- (9) Power Switch: Turn on or off the power source.
- (10) Air Condensate Filter/Trap Bowl.

Further Controls Explained

Main interface description

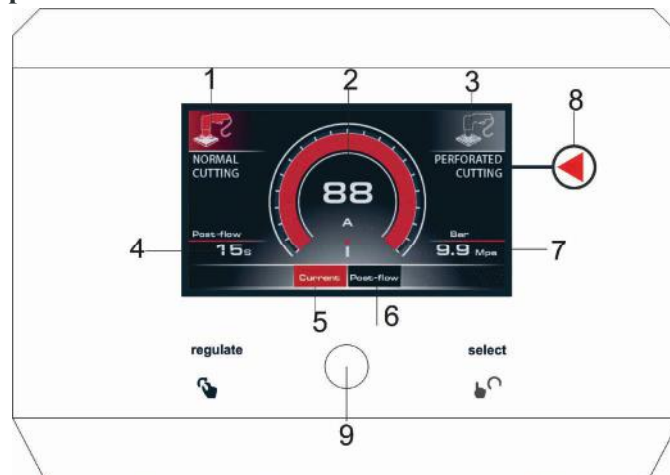



ADVANCECUT 125

- 1, Normal cutting model
- 2, Current parameter display area
- 3, Perforated cutting model
- 4, Post-flow display area
- 5, The regulating current is the display area(Press the knob to switch between 5 and 6)
- 6, The regulating Post-flow is the display area(Press the knob to switch between 5 and 6)
- 7, Barometric display area
- 8, Select mode button
- 9, Parameter setting knob

Compressed Air Testing/Setting button (8)



Long press button(8) for 2 seconds to enter the check gas, and the display screen will display the above interface

When positioned as 'set' compressed air control valve is open continuously. This is useful for testing and setting the air pressure without having to activate the trigger circuit. 'Run' position is normal operation.



AIR Error Display (1)

The above interface is displayed when the machine has no gas input or the air pressure is low.

Correct air pressure is critical for plasma cutting. Incorrect air pressure will cause poor cut quality, lack of cutting power, damage to the plasma torch and consumables and potentially damage the power source. Optimum air pressure is between 0.45 and 0.5MPa (65-75psi). Air pressure should be set with the air flowing through the torch, as the pressure with the air flowing will normally be



ADVANCECUT 125

less than static pressure, due to flow losses through the torch system. To unlock the pressure regulator knob in order to adjust it, pull the knob upwards. Once the pressure is set correctly, push the knob down again to lock it into place.

Torch Error Display (2)

Lights when issue with torch system or air supply detected and cutting output is disabled as a result. Flashing light means that torch shield cap is not installed. Continuous light means likely damaged or missing torch consumables or insufficient air pressure supply to the torch.

Alarm Error Display (3)

Lights when over voltage, over current or electrical overheating (due to exceeding duty cycle) is detected and protection is activated. When protection is activated, welding output will be disabled until the safety system senses the overload has reduced sufficiently and indicator lamp goes out. May also trigger if machine experiences an internal power circuit failure.

Phase loss Error Display (4)

System setup interface

Press the knob for 3 seconds to enter the setting interface, Switch the setting interface by pressing the button and set parameters by the knob.

Language selection interface (1)



Brightness adjustment interface (2)





ADVANCECUT 125

Information interface (3)



Machine reset interface (4)



Pilot Arc System

The AdvanceCut series of Air Plasma Cutting machines use a pilot arc system to establish the main cutting arc. A pilot arc system is a circuit where the return is back through the torch head and cable. This means it can create a small arc with some cutting power without making any electrical connection with the main machine earth. This is especially useful for starting cuts on material that does not have a good initial earth connection, such as paint, rust, scale.

Once the pilot arc is established and power is flowing back through the main earth, the pilot arc is switched off and the main arc started. Please note the pilot arc circuit is only designed to operate for short periods of time as an auxiliary starting system, so it has a safety protection that only allows the pilot arc to run for short periods at a time. In addition to this, these models also have a pilot arc controller system if the main arc cuts out and the torch remains to be triggered, the pilot arc will reignite. This is useful for cutting discontinuous workpieces like mesh or grids.

It is very important to recognize that plasma torch consumables wear as part of normal operation and should be replaced in a timely manner. Operating a torch with worn consumables will cause poor cutting results and possible damage to the torch and machine itself. Damage caused by



ADVANCECUT 125

untimely replacement of consumables will not be covered by warranty.

Use the following guidelines to determine when consumables should be replaced:

Cutting Tips: The cutting tip has a small calibrated orifice that the plasma passes through. If the orifice becomes partially blocked, deformed or enlarged, the cutting tip should be replaced.

Electrodes: The electrode has a small silver 'hafnium' insert in the end of the tip. This is what generates the plasma ions. Once the hafnium insert is gone or is damaged the tip must be replaced.

Swirl Ring/Retaining Cap: These should be replaced if broken, chipped, cracked or badly heat damaged.

Tips and electrodes: These should wear reasonably evenly and it is normal practice to replace them both together. If a new tip is inserted with a worn electrode the tip will wear much more quickly than if the electrode was also replaced at that same time. If tips or electrodes are wearing much faster than the other component it is likely to be caused by one of the following: poor operator technique, incorrect air supply or damaged torch head.

It is also very important to only use genuine Strata consumables and parts for the TH-125 torch. They are engineered to suit the machine and non-genuine items may cause lack of performance, short life span, torch and machine damage and void warranty.

2.2 Installation & Operation

Electrical Connection

The AdvanceCut series is designed to operate on a 3 phase 380V AC power supply.

When the power supply voltage is over the safe work voltage, there are over voltage and under voltage protection inside the welder, the alarm light will on, at the same time, the current output will be cut off.

If the power supply voltage continually goes beyond the safe work voltage range, it will shorten the welder life-span. The below measures can be used:

- Change the power supply input net. Such as, connect the welder with the stable power supply voltage of distributor;
- Induce the machines using power supply in the same time;
- Set the voltage stabilization device in the front of power cable input.



ADVANCECUT 125

Compressed Air Requirements

A reliable and consistent supply of clean dry compressed air is essential for proper operation. Although the machine contains its own internal air supply filtration system it is recommended the compressed air supply should have external filtration in the line feeding the machine, both a standard water trap (sintered bronze filter) and also a coalescing filter (for oil in air). The air requirement is a minimum of 120 l/min (4.5cfm) Free Air Delivery (FAD) at 75psi pressure. This normally means the compressor must be a belt drive model or if a direct drive it must have a motor power of 2.5HP or greater.

The air must be dry and free of oil and moisture (normally a symptom of older, worn out compressors). The air hose must also be of sufficient size (3/8"/10mm minimum) to supply the machine.

Basic Operation

- 1) Connect the earth cable quick connector to the earth connection socket. Connect the earth clamp to the work piece. Contact with the work piece must be firm contact with clean, bare metal, with no corrosion, paint or scale at the contact point.
- 2) Connect the plasma torch to the machine central connector ensuring the collar is done up firmly.
- 3) Connect the machine to suitable mains power using the mains input power lead. Switch the mains power switch to 'on' to power up the machine.
- 4) Connect the compressed air supply to the filter/ regulator inlet. Check the air pressure. Trigger the air flow using the 'set' function, check the air pressure again and adjust if necessary. Return the switch to 'run' position.
- 5) Select the output current using the current control knob. You are now ready to plasma cut!

Cutting Operation

After turning the Power Switch to the ON position and making control and air pressure adjustments, proceed as follows:

- 1) Hold the tip of the Torch within 3-4mm the work piece, at about 15- 30° angle to avoid damaging the tip.



ADVANCECUT 125

- 2) Depress the torch switch. (Air and the high frequency spark should energize).
- 3) As the high frequency spark jumps to the work piece, the main plasma arc will ignite and start cutting.
- 4) After starting the cut, the tip can be dragged along the work piece if cutting up to 3mm thick material. When cutting material greater than 3mm, maintain a 3.2mm tip-to-work (standoff) distance.
- 5) When ending a cut, the torch switch should be released and lifted off the work piece just before the end of the cut to minimize double-arcing which can damage the tip. This is to prevent the high frequency arc starting from reigniting after cutting arc extinguishes.
- 6) In the post-flow mode, the arc can be restarted immediately by depressing the torch switch.

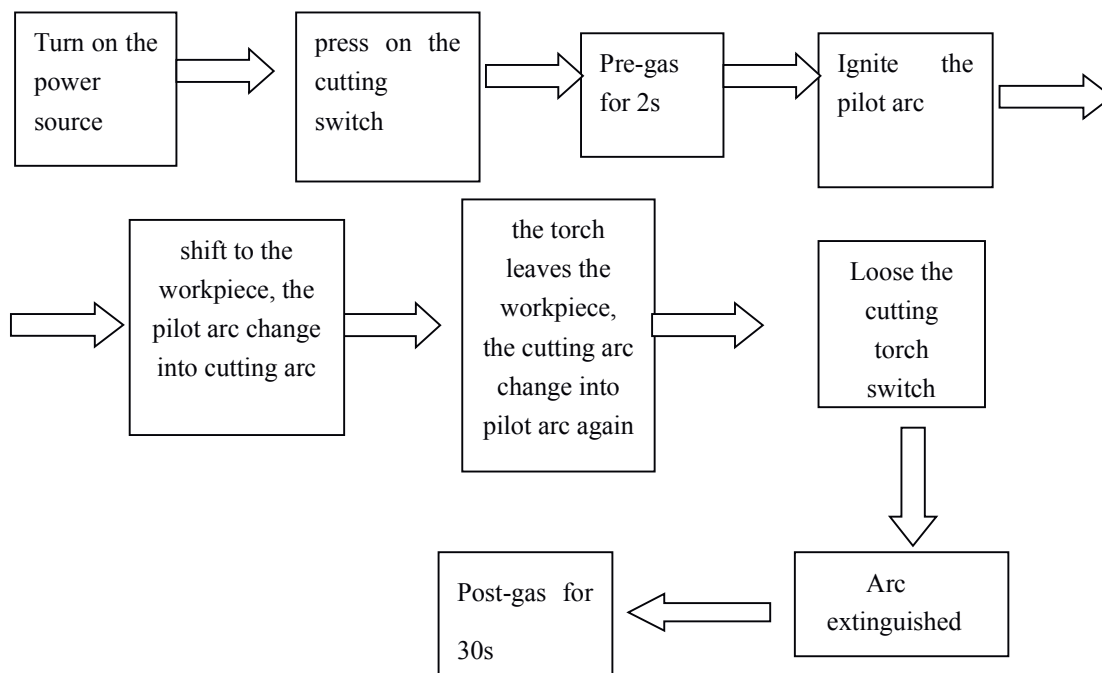

Note:

- The alarm lamp on when cutting, it is needed to loose the switch of the torch until the alarm release, then press on the switch to start cutting again.
- In the automatic gas test and examine, press on the cutting torch, there will no reflection.
- After a long usage, the surface of the electrode and nozzle will have oxidation reaction. Please replace the electrode and nozzle, for the alarm lamp will on when install the shield cup, and stop working,



ADVANCECUT 125

CNC Socket Diagram

AdvanceCut power supplies are equipped with an optional, factory-installed, four-position voltage divider that is designed to be safely connected without tools. The built-in voltage divider provides a scaled down arc voltage of 20:1, 30:1, 40:1, and 50:1 (maximum output of 18 V). An optional receptacle on the rear of the power supply provides access to the scaled down arc voltage and signals for arc transfer and plasma start.

Note:

The factory presets the voltage divider to 20:1. To change the voltage divider to a different setting, refer to the section on the next page.



The factory-installed internal voltage divider provides a maximum of 18V under opencircuit conditions. This is an impedance-protected functional extra low voltage (ELV) output to prevent shock, energy, and fire under normal conditions at the machineinterface receptacle and under single fault conditions with the machine interfacewiring. The voltage divider is not fault tolerant and ELV outputs do not comply with safety extra low voltage (SELV) requirements for direct connection to computerproducts.

Note:

The cover on the machine interface receptacle prevents dust and moisture from damaging the receptacle when not in use. This cover should be replaced if damaged or lost.

Installation of the machine interface cable must be performed by a qualified service technician. To install a machine interface cable:

1. Turn OFF the power and disconnect the power cord.
2. Remove the machine interface receptacle's cover from the rear of the power supply.
3. Connect the machine interface cable to the power supply.



ADVANCECUT 125

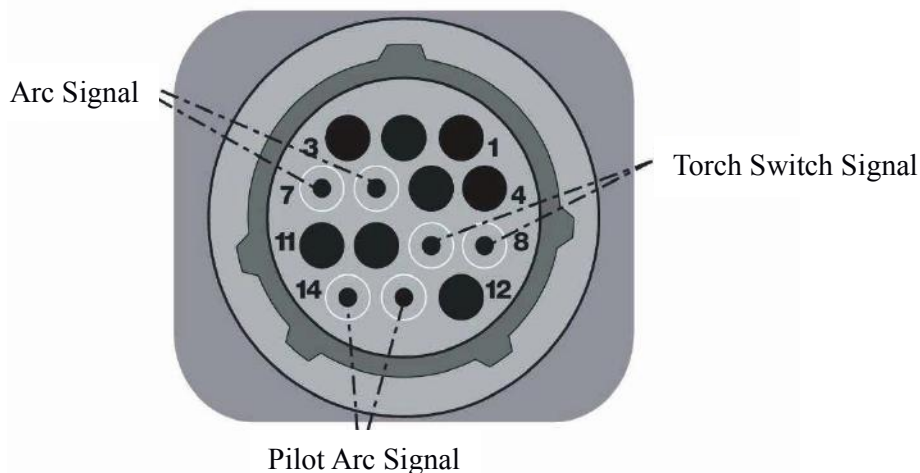

Refer to the following table when connecting the ADVANCECUT system to a torch height controller or CNC controller with a machine interface cable.

signal	type	Instruction	The connector socket	Cable ends
Start (start plasma)	Input	Normally open. 18 VDC open circuit voltage at START terminals. Requires dry contact closure to activate.	8、 9	8 (yellow)、 9 (green)
Transfer(start machine motion)	Output	Normally open. Dry contact closure when the arc transfers. 120 VAC/1 A maximum at the machine interface relay or switching device (supplied by the customer).	13、 14	13 (blue)、 14 (white)
Ground	Ground			
Voltage divider	Output	CUT: Divided arc signal of 20:1,30:1, 40:1, 50:1 (provides a maximum of 18 V).	6 (+)、 7 (-)	6 (red)、 7 (black)

Setting the five-position voltage divider on the ADVANCECUT125

The factory presets the voltage divider to 20:1. To change the voltage divider to a different setting:

1. Turn OFF the power supply and disconnect the power cord.
2. Remove the power supply cover.
3. Locate the voltage divider DIP switches on the left side of the power supply.





ADVANCECUT 125

Note: the table below for the shift and scale selection

scale selection dial number	20:1	30:1	40:1	50:1
1	ON	1	1	1
2	2	ON	2	2
3	3	3	ON	3
4	4	4	4	ON

2.3 Plasma Cutting Guide

2.3.1 Cutting Guide

Effect of Cutting Speed

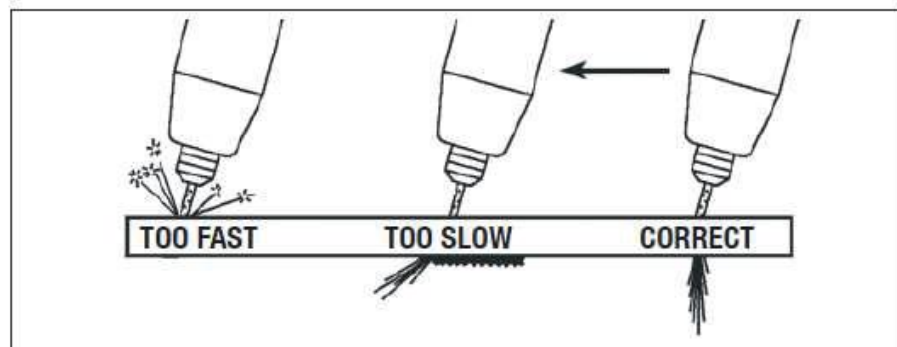

Piercing Technique

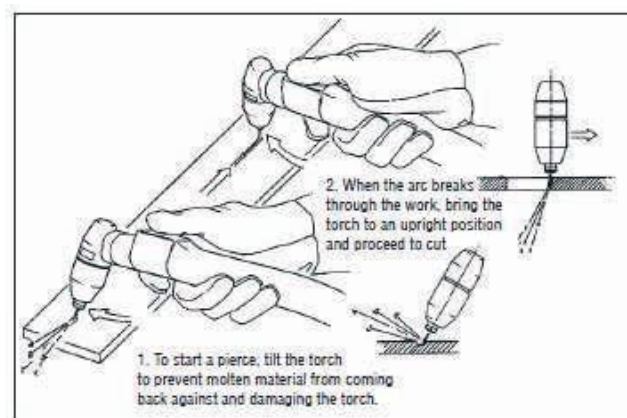



ADVANCECUT 125

NOTE: Keep moving while cutting. Cut at a steady speed without pausing. Maintain the cutting speed so that the arc lag is 10° to 20° behind the travel direction. Use a 5° - 15° leading angle in the direction of the cut.

2.3.2 Operating Techniques

1. **Piercing** - Materials (up to 3.2mm/1/8in. thick) work. When piercing thicker materials (up to 4.8mm stainless or carbon steel) at an angle, position the torch 0.5mm (.02") above the work piece.

It is advisable when piercing thicker materials to drill a small pilot/starting hole in the work piece which makes it a lot easier and gives increased tip life. Start the cutting arc, then immediately raise the torch to 1.6mm (1/16") stand-off and move the torch along the cut path. This will reduce the chance of spatter from entering the torch and prevent the possibility of welding the tip to the plate. The torch should be angled at about 30° when starting to pierce, and then straightened after accomplishing the pierce.

2. **Grate Cutting** - For rapid restarts, such as grate or heavy mesh cutting, do not release the torch switch. This avoids the 2 second pre-flow portion of the cutting cycle.
3. **Edge Starting** – For edge starts, hold the torch perpendicular to the work piece with the front of the tip near (not touching) the edge of the work piece at the point where the cut is to start. When starting at the edge of the plate, do not pause at the edge and force the arc to ‘reach’ for the edge of the metal.

Cutting Speed Guide		
Material	Thickness (mm)	Cutting Speed (mm/s)
Carbon Steel (AISI 1020)	1.6	150
	3.2	50
	6.4	20
Stainless Steel (AISI 304)	1.6	140
	3.2	40
	6.4	15
Aluminium (6061)	1.6	190
	3.2	85
	6.4	30



ADVANCECUT 125

Note: The speeds given here are typical for best quality cuts. Your actual speeds may vary depending on material composition, surface condition, operator technique, etc. If cutting speed is too fast, you may lose the cut. With slower speeds excessive dross may accumulate. If speed is too slow, the arc may extinguish. Air cutting typically produces a rough face on stainless steel and aluminium.

Establish the Cutting Arc as Quickly as Possible.

- 4. Drag Cutting** - Position torch tip slightly above work piece, press torch switch and lower torch tip forward work piece until contact is made and cutting arc is established. After cutting arc is established, move the torch in the desired direction keeping the torch tip slightly angled, maintaining contact with the work piece. Avoid moving too fast as would be indicated by sparks radiating from the topside of the work piece. Move the torch just fast enough to maintain sparks concentration at the underside of the work piece and making sure the material is completely cut through before moving on. Adjust drag speed as desired/ required.
- 5. Direction of Cut** - The plasma gas stream swirls as it leaves the torch to maintain a smooth column of gas. This swirl effect results in one side of a cut being more square than the other. Viewed along the direction of travel, the right side of the cut is more square than the left.

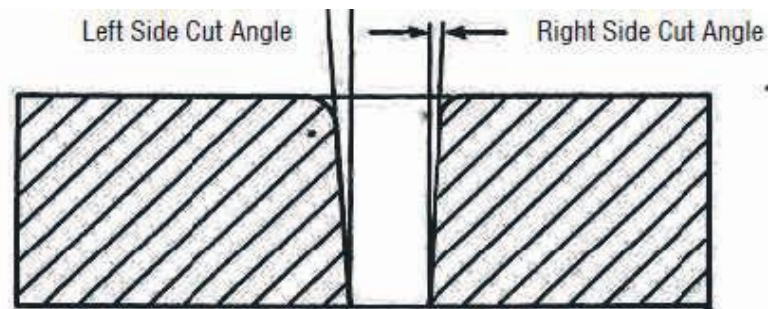

To make a square-edged cut along an inside diameter of a circle, the torch should move counter clockwise around the circle. To keep the square edge along an outside diameter cut, the torch should travel in a clockwise direction.

- 6. Quality Cuts** - Dross (slag) is the excess material that spatters and builds up on the underside of the work-piece as you cut. Dross occurs when the operating procedure and technique is less than optimal. It will require practice and experience to obtain cuts without dross. Although less than optimal cuts will contain dross, it is relatively easy to remove by breaking it off using pliers or chipping off with a chisel or scraping or grinding the finished cut as needed and is generally only a minor inconvenience.



ADVANCECUT 125

A combination of factors contributes to the build-up of dross. They include; material type, material thickness, amperage used for the cut, speed of the torch across the work-piece, condition of the torch tip, input line voltage, air pressure, etc. Generally there is an inversely proportional relationship between output current and speed of cut. Do not use more output current than is necessary and adjust speed of cut toward minimizing dross build-up on underside of cut. Experiment with adjusting current and speed to minimize dross.

When dross is present on carbon steel, it is commonly referred to as either 'high speed, slow speed, or top dross'. Dross present on top of the plate is normally caused by too great a torch to plate distance.

'Top dross' is normally very easy to remove and can often be wiped off with a welding glove. 'Slow speed dross' is normally present on the bottom edge of the plate. It can vary from a light to heavy bead, but does not adhere tightly to the cut edge, and can be easily scraped off. 'High speed dross' usually forms a narrow bead along the bottom of the cut edge and is very difficult to remove. When cutting troublesome steel, it is sometimes useful to reduce the cutting speed to produce 'slow speed dross'. Any resultant clean up can be accomplished by scraping, not grinding.

2.4 Troubleshooting

Trouble	Possible Reason	Suggested Remedy
Torch will not come on	<ol style="list-style-type: none"> 1. Power switch OFF 2. Air supply is not of sufficient volume or pressure 3. Work piece ground clamp not attached. 	<ol style="list-style-type: none"> 1. Turn power switch to the ON position 2. Check air supply (60–80 PSI, 3.5cfm required) 3. Attach to work piece or to steel table with work piece securely clamped to table
Sparks are shooting upward instead of down through the material.	<ol style="list-style-type: none"> 1. Plasma torch is not piercing the material 2. Torch may be too far away from the work piece 3. Material may not be earthed properly 4. Travel speed too fast 	<ol style="list-style-type: none"> 1. Increase current 2. Decrease the distance of your torch to the work piece 3. Check connections for proper earth 4. Reduce speed
Beginning of cut not completely pierced	Possible earth connection problem	Check all connections
Dross build-up on parts of cuts	<ol style="list-style-type: none"> 1. Tool/material building up heat 2. Cutting speed too slow or current too high 3. Worn torch parts 	<ol style="list-style-type: none"> 1. Allow material to cool then continue cut. 2. Increase speed and/or reduce current until dross is reduced to minimum 3. Inspect and repair or replace worn parts



ADVANCECUT 125

Arc stops while cutting	<ol style="list-style-type: none"> 1. Cutting speed too slow 2. Torch is too high, away from material 3. Worn torch parts 4. Work piece earth cable disconnected 	<ol style="list-style-type: none"> 1. Increase speed until problem solved 2. Lower torch to recommended height 3. Inspect and repair or replace worn parts 4. Connect work piece earth clamp to work piece or steel table.
Insufficient penetration	<ol style="list-style-type: none"> 1. Cutting speed too fast 2. Torch tilted too much 3. Metal too thick for plasma capacity 4. Worn torch parts 	<ol style="list-style-type: none"> 1. Slow down travel speed 2. Adjust tilt 3. Several passes may be necessary 4. Inspect and repair or replace worn parts
Arc sputters/flares	Water in the air supply	Install air drier or additional filtration
Consumables wear quickly	<ol style="list-style-type: none"> 1. Exceeding unit capability 2. Excessive ARC starting HF use 3. Improperly assembled torch 4. Inadequate air supply, pressure too low 5. Faulty air compressor 	<ol style="list-style-type: none"> 1. Material too thick, increase angle to prevent blow back into torch tip 2. Do not operate HF ARC starting for more than 3 seconds – you can also start with torch in contact with metal or within 1/16” of metal 3. See section ‘Replacing Consumables’ 4. Check air filters, increase air pressure 5. Check air compressor operation and make sure input air pressure is at least 100 PSI
Circuit breaker/fuse trips while operating	Extension cord being used is not heavy duty	Use a heavy duty extension cord (2.5mm diameter)

If you have any problems in setting up or operating the machine, please first re-consult this manual.

2.5 Operation environment

- ▲ Height above sea level ≤ 1000 M
- ▲ Operation temperature range $-10 \sim +40^{\circ}\text{C}$
- ▲ Air relative humidity is below 90 % (20°C)
- ▲ Preferable site the machine some angles above the floor level, the maximum angle does not exceed 15 .
- ▲ Protect the machine against heavy rain AND against direct sunshine.
- ▲ The content of dust, acid, corrosive gas in the surrounding air or substance cannot exceed normal standard.
- ▲ Take care that there is sufficient ventilation during welding. There must be at least 30cm free distance between the machine and wall.

2.6 Operation Notices

- ▲ Read Section §1 carefully before starting to use this equipment.



ADVANCECUT 125

- ▲ Connect the ground wire with the machine directly.
- ▲ Ensure that the input is three-phase: 50/60Hz, 400V \pm 10%.
- ▲ Before operation, none concerned people should not be around the working area and especially children. Do not watch the arc in unprotected eyes.
- ▲ Ensure good ventilation of the machine to improve Duty Cycle.
- ▲ Turn off the engine when the operation finished for energy consumption efficiency.
- ▲ When power switch shuts off protectively because of failure. Don't restart it until problem is resolved. Otherwise, the range of problem will be extended.
- ▲ In case of problems, contact your local dealer if no authorized maintenance staff is available!



3 Maintenance & Troubleshooting

3.1 Cutting gun maintenance

Warning : 1. Check the consumable parts for damage, if worn, replace it.

2. Turn off the power source before check or remove cutting gun parts

Note: When operating the torch in a normal condition, a small amount of gas vents through the gap between the shield cup and the torch handle, Do not attempt to over tighten the shield cup as irreparable damage to internal components may result.

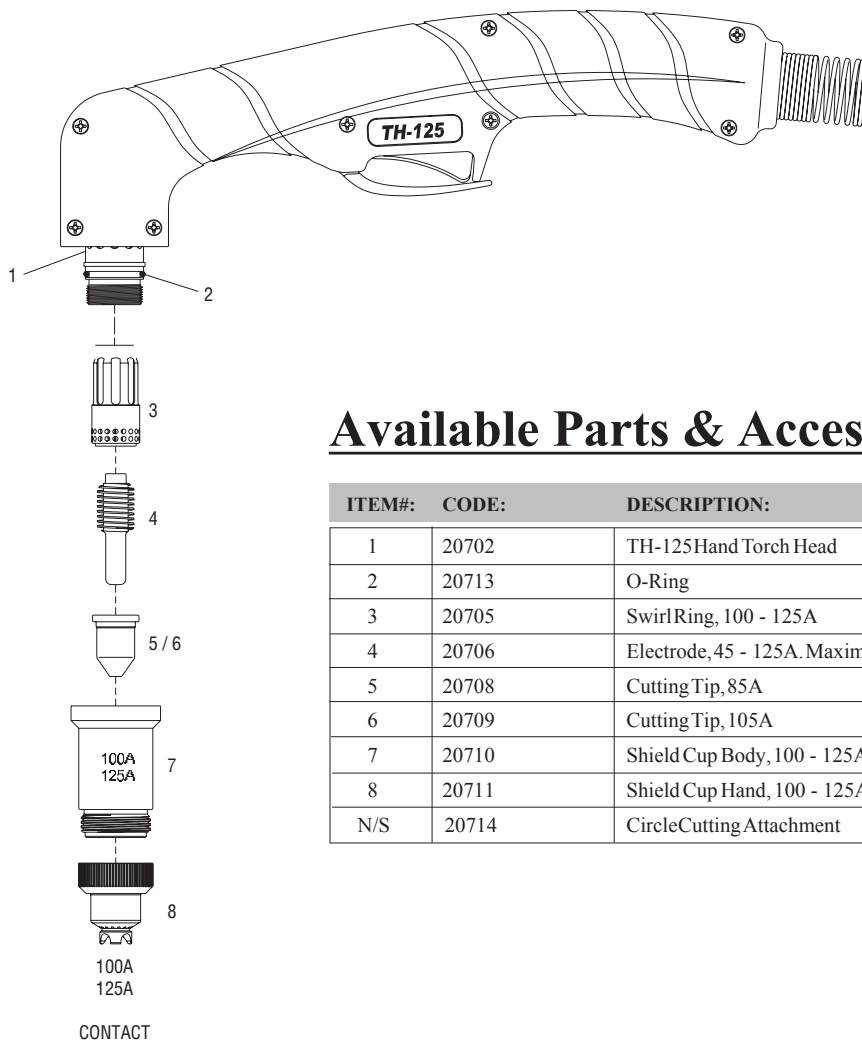

Available Parts & Accessories

ITEM#:	CODE:	DESCRIPTION:
1	20702	TH-125Hand Torch Head
2	20713	O-Ring
3	20705	SwirlRing, 100 - 125A
4	20706	Electrode, 45 - 125A. MaximumLife
5	20708	Cutting Tip, 85A
6	20709	Cutting Tip, 105A
7	20710	Shield Cup Body, 100 - 125A
8	20711	Shield Cup Hand, 100 - 125A
N/S	20714	CircleCutting Attachment

3.2 Troubleshooting Principle



WARNING

There are extremely dangerous voltage and power levels present inside this unit. Do not attempt to diagnose or repair unless you have had training in power electronics measurement and troubleshooting techniques.



ADVANCECUT 125

A. Power lamp and temperature lamp on.

1. Air flow blocked, check for blocked air flow around the unit and correct condition.
2. Fan blocked, check and correct condition.
3. Unit is overheated, let unit cool down for at least 5 minutes. Make sure the unit has not been operated beyond Duty Cycle limit, refer to technology parameters in Section 2.
4. Faulty components in unit, return for repair or have qualified technician repair per Service Manual.

B. Torch fails to ignite the arc when torch switch is activated

1. System is in SET mode, change to RUN mode.
2. Faulty torch parts, inspect torch parts and replace if necessary.
3. Gas pressure too high or too low, adjust to proper pressure.
4. Faulty components in unit, return for repair or have qualified technician repair per Service Manual.

C. No cutting output; Torch activated, power source on; Gas flows; Fan operates

1. Torch not properly connected to power supply, check that torch leads are properly connected to power supply.
2. Work cable not connected to work piece, or connection is poor, make sure that work cable has a proper connection to a clean, dry area of the workpiece.
3. Faulty components in unit, return for repair or have qualified technician repair per Service Manual.
4. Faulty Torch, return for repair or have qualified technician repair.

D. Low cutting output

1. Incorrect setting of CURRENT (A) control, check and adjust to proper setting.
2. Faulty components in unit, return for repair or have qualified technician repair.



ADVANCECUT 125

E. Difficult Starting

1. Worn torch parts (consumables), shut off input power. Remove and inspect torch shield cup, tip and electrode. Replace electrode or tip if worn; replace shield cup if excessive spatter adheres to it.

F. Arc shuts off during operation; arc will not restart when torch switch is activated.

1. Power Supply is overheated, let unit cool down for at least 5 minutes. Make sure the unit has not been operated beyond Duty Cycle limit. Refer to Section 2 for duty cycle specifications.
2. Gas pressure too low, check source for at least 4bar/60psi; adjust as needed. It is need to open the machine cover.
3. Torch consumables worn, check torch shield cup, tip, starter element, and electrode; replace asneeded.
4. Faulty components in unit., return for repair or have qualified technician repair per Service Manual.

G. No gas flow; the power lamp on; Fan operates

1. Gas not connected or pressure too low, check gas connections. Adjust gas pressure to proper setting

H. Torch cuts but low quality

1. Current (A) control set too low, increase current setting.
2. Torch is being moved too fast across workpiece, reduce cutting speed.
3. Excessive oil or moisture in torch, hold torch 1/8 inch (3 mm) from clean surface while purging and observe oil or moisture buildup (do not activate torch). If there are contaminants in the gas, additional filtering may be needed.

3.3 Electrical schematic drawing

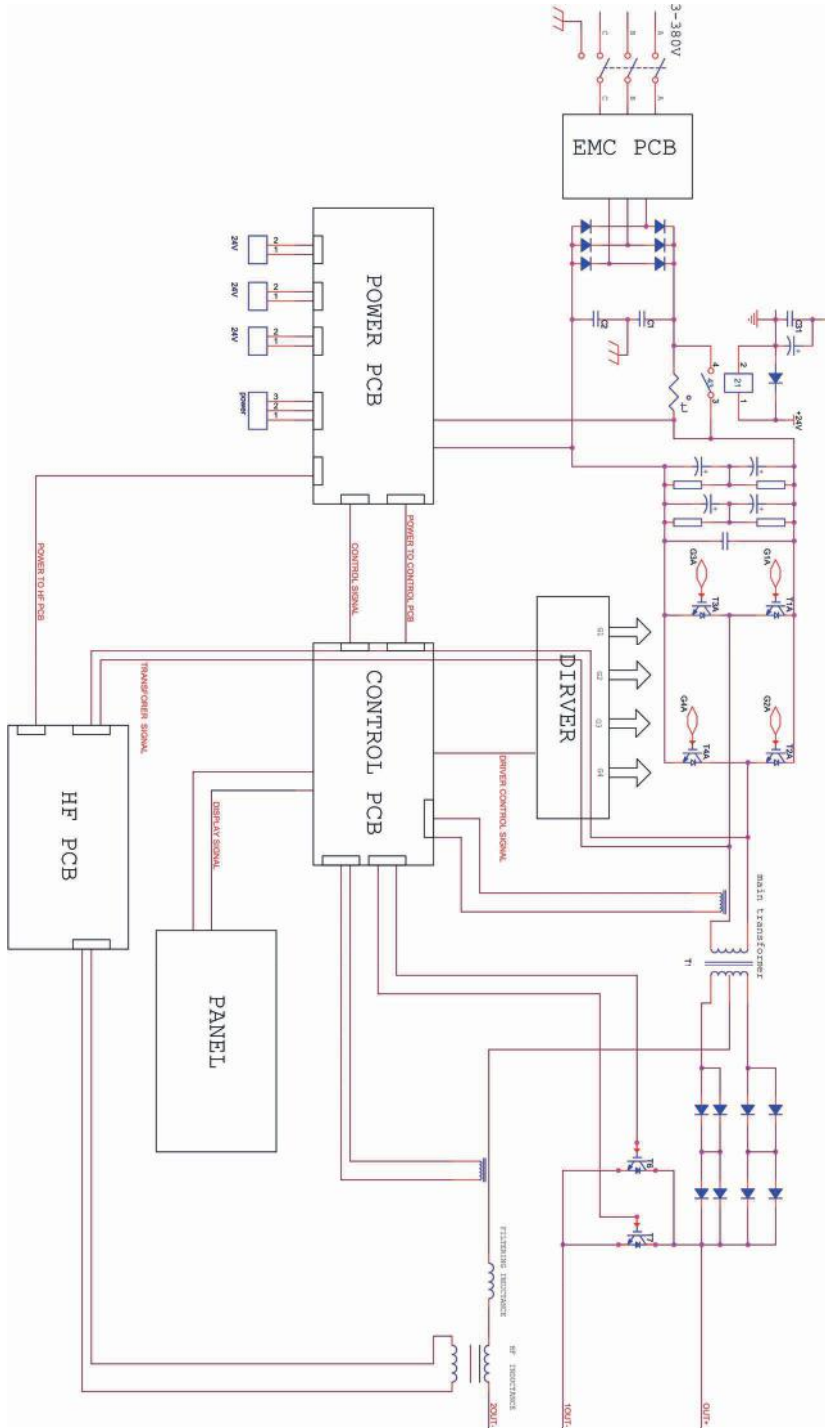



4 Safety

Welding and cutting equipment can be dangerous to both the operator and people in or near the surrounding working area, if the equipment is not correctly operated. Equipment must only be used under the strict and comprehensive observance of all relevant safety regulations. Read and understand this instruction manual carefully before the installation and operation of this equipment.

4.1 Symbols Explanation



- The above symbols mean warning!

Notice! Running parts, getting an electric shock or making contacts with thermal parts will cause damage to your body and others. The underline message is as follows:

Welding is quite a safe operation after taking several necessary protection measures!

4.2 Machine Operating warnings!

- The following symbols and words explanations are for some damages to your body or others, which could happen during the welding operation. While seeing these symbols, please remind yourself and others to be careful.
- Only people who are trained professionally can install, debug, operate, maintain and repair the welding equipment covered with this Operator's Manual!
- During the welding operation, non-concerned people should NOT be around, especially children!
- After shutting off the machine power, please maintain and examine the equipment according to 4 because of the DC voltage existing in the electrolytic capacitors at the output of the power supply!



ADVANCECUT 125



ELECTRIC SHOCK CAN KILL.

Touching live electrical parts can cause fatal shocks or severe burns. The electrode and work circuit is electrically live whenever the output is on. The input power circuit and internal machine circuits are also live when power is on. In Mig/Mag welding, the wire, drive rollers, wire feed housing, and all metal parts touching the welding wire are electrically live. Incorrectly installed or improperly grounded equipment is dangerous.

- Never touch live electrical parts.
- Wear dry, hole-free gloves and clothes to insulate your body.
- Be sure to install the equipment correctly and ground the work or metal to be welded to a good electrical (earth) ground according to the operation manual.
- The electrode and work (or ground) circuits are electrically “hot” when the machine is ON. Do not touch these “hot” parts with your bare skin or wet clothing. Wear dry, hole-free gloves to insulate hands.
- In semiautomatic or automatic wire welding, the electrode, electrode reel, welding head, nozzle or semiautomatic welding gun are also electrically “hot”.
- Insulate yourself from work and ground using dry insulation. Make certain the insulation is large enough to cover your full area of physical contact with work and ground.
- Be Careful when using the equipment in small places, falling-off and wet circumstance.
- Always be sure the work cable makes a good electrical connection with the metal being welded. The connection should be as close as possible to the area being welded.
- Maintain the electrode holder, work clamp, welding cable and welding machine in good, safe operating condition. Replace damaged insulation.
- Never dip the electrode in water for cooling.
- Never simultaneously touch electrically “hot” parts of electrode holders connected to two welders because voltage between the two can be the total of the open circuit voltage of both welders.
- When working above the floor level, use a safety belt to protect yourself from a fall should you get an electric shock!



ADVANCECUT 125



FUMES AND GASES CAN BE DANGEROUS.

Smoke and gas generated whilst welding or cutting can be harmful to people's health. Welding produces fumes and gases. Breathing these fumes and gases can be hazardous to your health.

- Do not breathe the smoke and gas generated whilst welding or cutting, keep your head out of the fumes. Use enough ventilation and/or exhaust at the arc to keep fumes and gases away from the breathing zone. When welding with electrodes which require special ventilation such as stainless or hard facing or on lead or cadmium plated steel and other metals or coatings which produce highly toxic fumes, keep exposure as low as possible and below the Threshold Limit Values using local exhaust or mechanical ventilation. In confined spaces or in some circumstances, outdoors, a respirator may be required. Additional precautions are also required when welding on galvanized steel.
- Do not weld in locations near chlorinated hydrocarbon vapors coming from degreasing, cleaning or spraying operations. The heat and rays of the arc can react with solvent vapors to form phosgene, a highly toxic gas, and other irritating products.
- Shielded gases used for arc welding can displace air and cause injury or death. Always use enough ventilation, especially in confined areas, to insure breathing air is safe.
- Read and understand the manufacturer's instructions for this equipment and the consumables to be used, including the material safety data sheet and follow your employer's safety practices.



ARC RAYS: Harmful to people's eyes and skin.

Arc rays from the welding process produce intense visible and invisible ultraviolet and infrared rays that can burn eyes and skin.

- Use a shield with the proper filter and cover plates to protect your eyes from sparks and the rays of the arc when welding or observing open arc welding.
- Use suitable clothing made from durable flame-resistant material to protect your skin and that of your coworkers from the arc rays.
- Protect other nearby personnel with suitable, non-flammable screening and /or warn them not to



ADVANCECUT 125

watch the arc nor expose themselves to the arc rays or to hot spatter or metal.



SELF-PROTECTION

- Keep all equipment safety guards, covers and devices in position and in good repair. Keep hands, hair, clothing and tools away from V-belts, gears, fans and all other moving parts when starting, operating or repairing equipment.
- Do not put your hands near the engine fan. Do not attempt to override the governor or idler by pushing on the throttle control rods while the engine is running.



DO NOT add any fuel near an open-flame welding arc or when the engine is running. Stop the engine and allow it to cool before refueling to prevent spilled fuel from vaporizing on contact with hot engine parts and igniting. Do not spill fuel when filling tank. If fuel is spilled, wipe it up and do not start engine until fumes have been eliminated.



WELDING SPARKS can cause fire or explosion.

Welding on closed containers, such as tanks, drums, or pipes, can cause them to explode. Flying sparks from the welding arc, hot work piece, and hot equipment can cause fires and burns. Accidental contact of electrode to metal objects can cause sparks, explosion, overheating, or fire. Check and be sure the area is safe before doing any welding

- Remove fire hazards material from the welding area. If this is not possible, cover them to prevent the welding sparks from starting a fire. Remember that welding sparks and hot materials from welding can easily go through small cracks and openings to adjacent areas. Avoid welding near hydraulic lines. Have a fire extinguisher readily available.
- Where compressed gases are to be used at the job site, special precautions should be used to prevent hazardous situation.
- When not welding, make certain no part of the electrode circuit is touching the work or ground. Accidental contact can cause overheating and create a fire hazard.
- Do not heat, cut or weld tanks, drums or containers until the proper steps have been taken to



ADVANCECUT 125

insure that such procedures will not cause flammable or toxic vapors from substances inside. They can cause an explosion even though they have been “cleaned”.

- Vent hollow castings or containers before heating, cutting or welding. They may explode.
- Sparks and spatter are thrown from the welding arc. Wear oil free protective garments such as leather gloves, heavy shirt, cuff less trousers, high shoes and a cap over your hair. Wear earplugs when welding out of position or in confined places. Always wear safety glasses with side shields when in a welding area.
- Connect the work cable to the work as close to the welding area as practical. Work cables connected to the building framework or other locations away from the welding area increase the possibility of the welding current passing through lifting chains, crane cables or other alternate circuits. This can create fire hazards or overheat lifting chains or cables until they fail.



Rotating parts may be dangerous.

- Use only compressed gas cylinders containing the correct shielding gas for the process used and properly operating regulators designed for the gas and pressure used. All hoses, fittings, etc. should be suitable for the application and maintained in good condition.
- Always keep cylinders in an upright position securely chained to an undercarriage or fixed support.
- Cylinders should be located:
 - Away from areas where they may be struck or subjected to physical damage.
 - At a safe distance from arc welding or cutting operations and any other source of heat, sparks, or flame.
- Never allow the electrode, electrode holder or any other electrically “hot” parts to touch a gas cylinder.
- Keep your head and face away from the cylinder valve outlet when opening the cylinder valve.
- Valve protection caps should always be in place and hand tight except when the cylinder is in use or connected for use.



ADVANCECUT 125



Gas Cylinders.

Shielding gas cylinders contain gas under high pressure. If damaged, a cylinder can explode. Because gas cylinders are normally part of the welding process, be sure to treat them carefully. CYLINDERS can explode if damaged.

- Protect gas cylinders from excessive heat, mechanical shocks, physical damage, slag, open flames sparks, and arcs.
- Insure cylinders are held secure and upright to prevent tipping or falling over.
- Never allow the welding electrode or earth clamp to touch the gas cylinder, do not drape welding cables over the cylinder.
- Never weld on a pressurised gas cylinder, it will explode and kill you.
- Open the cylinder valve slowly and turn your face away from the cylinder outlet valve and gas regulator.



Gas build up.

The build up of gas can causes a toxic environment, deplete the oxygen content in the air resulting in death or injury. Many gases use in welding are invisible and odourless.

- Shut off shielding gas supply when not in use.
- Always ventilate confine spaces or use approved air-supplied respirator.



Electric and Magnetic Fields.

Electric current flowing through any conductor causes localized Electric and Magnetic Fields (EMF). The discussion on the effect of EMF is ongoing in the entire world. Up to now, no material evidences show that EMF may have effects on health. However, the research on the effect of EMF is still ongoing. Before any conclusion, we should minimize exposure to EMF as few as possible.

In order to minimize EMF, we should use the following procedures:



ADVANCECUT 125

- Route the electrode and work cables together – Secure them with tape when possible.
- All cables should be put away and far from the operator.
- Never coil the power cable around your body.
- Make sure welding machine and power cable to be far away from the operator as far as possible according to the actual circumstance.
- Connect the work cable to the workpiece as close as possible to the area being welded.
- The people with heart-pacemaker should be away from the welding area.



Noise can damage hearing.

Noise from some processes or equipment can damage hearing. You must protect your ears from loud noise to prevent permanent loss of hearing.

- To protect your hearing from loud noise, wear protective ear plugs and/or ear muffs. Protect others in the workplace.
- Noise levels should be measured to be sure the decibels (sound) do not exceed safe levels.



Hot parts.

Items being welded generate and hold high heat and can cause severe burns. Do not touch hot parts with bare hands. Allow a cooling period before working on the welding gun. Use insulated welding gloves and clothing to handle hot parts and prevent burns.

4.3 EMC device classification



Radiation Class A Device.

- Only can be used in the industrial area
- If it is used in other area, it may cause connection and radiation problems of circuit.

Radiation Class B device.

- It can meet the radiation requirements of residential area and industrial area. It also can be used in residential area which power is supplied by public low voltage circuit.



ADVANCECUT 125

EMC device can be classified by power nameplate or technical data.

Hander welding machines belong to Class A.

4.4 EMC measure



In the special situation, The specified area may be affected, the standard of radiation limit value has been complied with (eg: The device, which is easy effected by electromagnetism, is used at the installation location, or there is radio or TV near the installation location). In this condition, the operator should adopt some appropriate measures to remove interference.

Accoring to the domestic and international standards, the ambient devices' electromagnetism situation and anti-interference ability must be checked :

- Safety device
- Power line, Signal transmission line and Data transmission line
- Data processing equipment and telecommunication equipment
- Inspection and calibration device

The effective measures avoid the problem of EMC :

a) Power source

Even though the power source connection meet rules, we still need to take additional measure to remove the electromagnetic interference. (eg: Use the right power filter.)

b) The welding line

- Try to shorten the length of cable
- Put the cable together
- Be Far away from other cable

c) Equipotential connection

d) Ground connection of work-piece

- When necessary, use appropriate capacitance to connect the ground.

e) Shielding, when necessary

- Shield the ambient devices
- Shield the whole welding machine



ADVANCECUT 125

4.5 Warning label

The device with a warning label. Do not remove, destroy or cover this label. These warnings are intended to avoid incorrect device operations that could result in serious personal injury or property damage.

	WARNING! For protecting you and others, please read the label and instruction.
	 Welding dust and gas is hazardous to health. Head should be disengaged the welding dust. Use aerator to avoid the resting-place or working-place polluted.
	 ARC radial can stab the eyes and damage your skin. Wear protective clothing for your eye, your ear, and your body.
	ELECTRIC SHOCK CAN KILL Do not touch the position with electric, include electric. Turn off the power breaker out of the machine before maintenance.
	 Sparks can cause explosion. A safe distance from welding area and any other source of sparks or flame.
ADDITIONAL SAFE NOTICE	
<ul style="list-style-type: none">• Reading and well note the operation manual.• Do not operate when the cover and panel opened.• Only qualified person can install, use and maintenance the machine.• Clear away the dust on the machine twice a month. (by the air compressor)	
DO NOT MOVE THIS LABEL.	



ADVANCECUT 125

Warranty

As part of an on-going commitment to excellence in product support, Euroquip offers a comprehensive product warranty program.

In order to qualify for full warranty support, your product must be registered. Product not registered with Euroquip is supported by a base 12 month warranty only. Spare parts and technical support will not be available for an unregistered product outside of this base warranty period. If a Euroquip dealer has not already registered your product, please register it online or download a physical registration form at www.euroquip.co.nz.

Registered warranty period for the ADVANCECUT 75:

Commercial Use: 36 Months

Domestic Use: 36 Months

Warranty covers failure caused by manufacturing and material defects in the product, during the warranty period specified. The warranty period begins when the product is purchased by the end user. Warranty is not transferrable and is only claimable by the original purchaser.

Warranty does not cover parts that are subject to wear and tear from usage.

Warranty covers failure of a product caused by defective materials and/or manufacturing for the period given and the usage specified by Euroquip. The warranty period begins when the product is purchased by the end user. Warranty is not transferrable and is only claimable by the original purchaser.

Warranty also does not cover failure caused by the untimely replacement or service of the above wearing parts. Evidence must be provided that the product has been maintained and serviced suitably for a claim to be considered under warranty.

Failure caused by incorrect operation of the product, lack of proper care and maintenance of the product, external damage, external circumstances such as contaminated fuel or poor water supply, modifications to the product, attempted repair/ service by a party other than an Approved Service Agent, is not covered under warranty.

Warranty does not cover pre delivery service and adjustment, or failure that may occur as a result of lack of/ incorrect pre delivery service and adjustment.

Warranty does not cover any incidental, indirect or consequential loss, damage or expense that may result from any defect, failure or malfunction of a product.

Should any issue be found to be a combination of a warranty failure and a non-warranty issue, the repair cost component to rectify and repair the non-warranty failure is the customers' full responsibility.

The decision that an issue with a product qualifies as a warranty claim is made at the sole jurisdiction of Euroquip.

No costs incurred will be considered under warranty if repairs are carried out by a party other than a Euroquip Approved Service Agent, unless with prior consent in writing from Euroquip.

It is the responsibility of the purchaser to deliver a product under warranty to the nearest relevant service agent or product reseller. Warranty does not cover call outs, mile-age and freight costs.

If a product is repaired under warranty, parts and labour required for the repair will be supplied at no charge. Warranty assessment and repair will be scheduled and executed according to the normal work flow at the service location and depending on the availability of suitable replacement parts.

This warranty policy is an additional benefit and does not affect the legal rights of any end user, reseller or service agent.



Scan here to register your product

<http://www.euroquip.co.nz/Contact+Us/Product+Registration+Form.html>



ADVANCECUT 125



ADVANCECUT 125



ADVANCECUT 125



Congratulations on your new STRATA product. We are proud to have you as our customer and will strive to provide you with the best service and reliability in the industry. This product is backed by our extensive warranty. To locate your nearest distributor or service agency visit www.strata.co.nz, or email us at CustomerService@euroquip.co.nz

www.strata.co.nz